

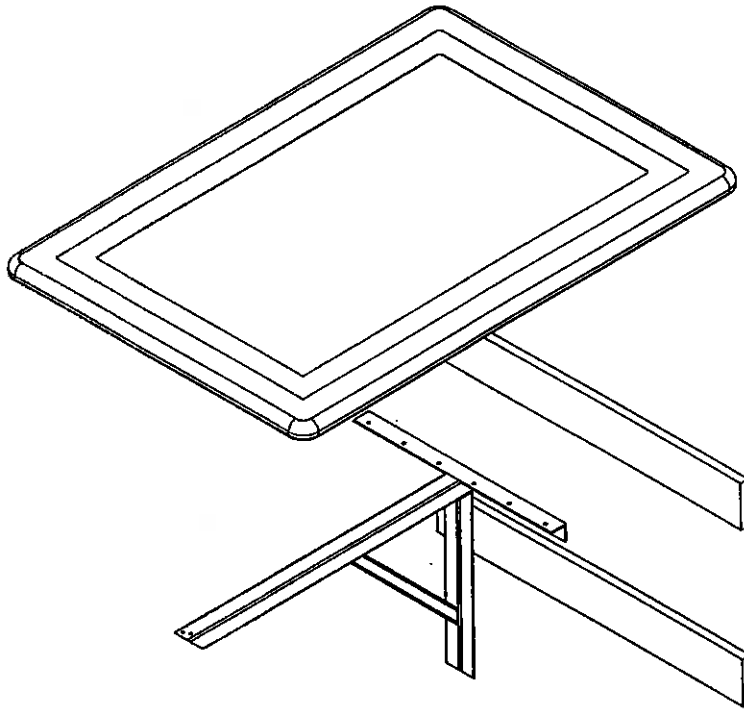

your source for furnishing solutions

INSTALLATION INSTRUCTION

***PRODUCT :WALL MOUNT CANTILEVER
Z000000051***



***ATTENTION INSTALLERS: PLEASE PRESENT INSTALLATION DOCUMENTS TO FACILITIES
MANAGER.***

***REVISION:
DATE:***

WALL MOUNT CANTILEVER COLLECTION

Installation Instructions:

UNPACKING YOUR SHIPMENT

Unpack and identify each part in each box that you have received. If your shipment is missing parts, or too many parts were shipped, please contact Plymold.

COMPONENT IDENTIFICATION:

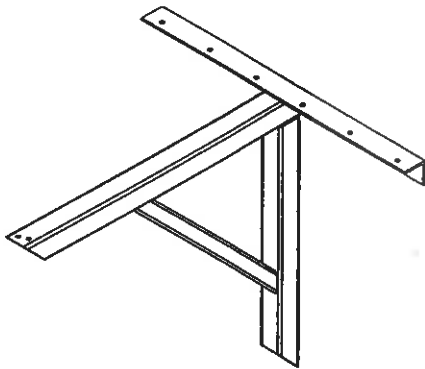

20" CANTILEVER

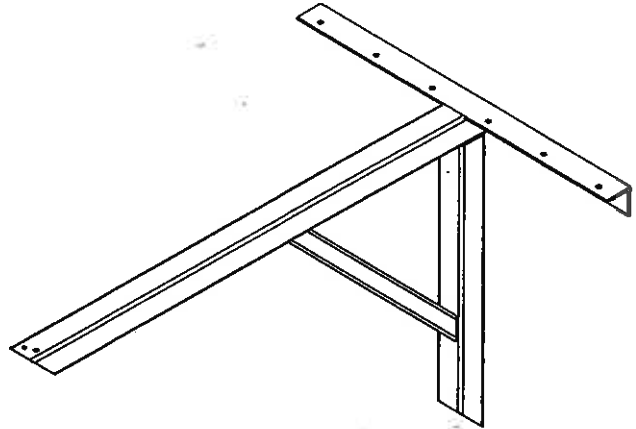

28" CANTILEVER

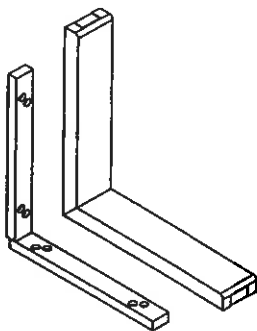

12" CANTILEVER W/COVER

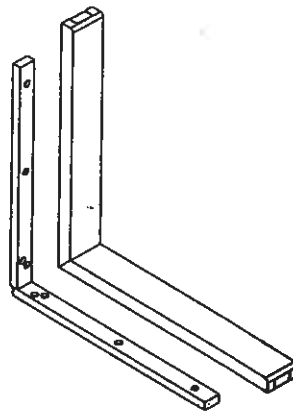

18" CANTILEVER W/COVER

TOOLS REQUIRED:

- Hammer
- Stud finder
- Screw Gun w/#2 Phillips Bit
- Pencil or Marker
- Tape Measure
- Chalk line

STEP #1: Wall Prep For Drywall Attachment

- 1) Measure the appropriate distance up the wall and place marks near where the ends of the counter are going to be.
- 2) For stool height counters, mark on wall 40 3/4" and 25 3/4" off floor.
- 3) For chair height counters, mark on wall 28 3/4" and 13 3/4" off floor.
- 4) Using chalk line snap a line through marks on wall.
- 5) To insure proper cantilever to wall strength, secure a strip of 3/4" plywood to wall at cantilever attachment points. (plywood, not supplied) **NOTE:** Strips must span at least two studs in the wall.
- 6) For 20" and 28" wall mount cantilever cut 3/4" plywood strips 4" wide by counter length
- 7) For 12" wall mount cantilever cut 3/4" plywood strip 12 3/4" wide by counter length.
- 8) For 18" wall mount cantilever cut 3/4" plywood strip 18 3/4" wide by counter length.

Note: To insure proper cantilever strength wall bracing is required.

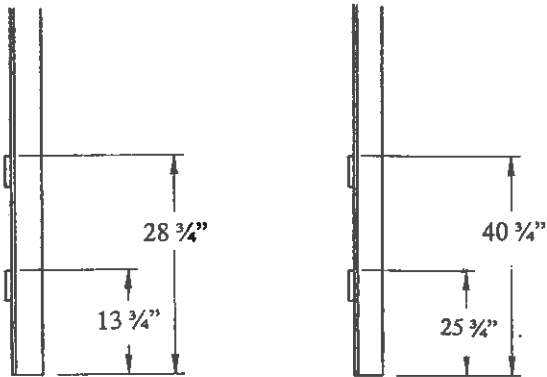

Counter height for chairs

Counter height for stools

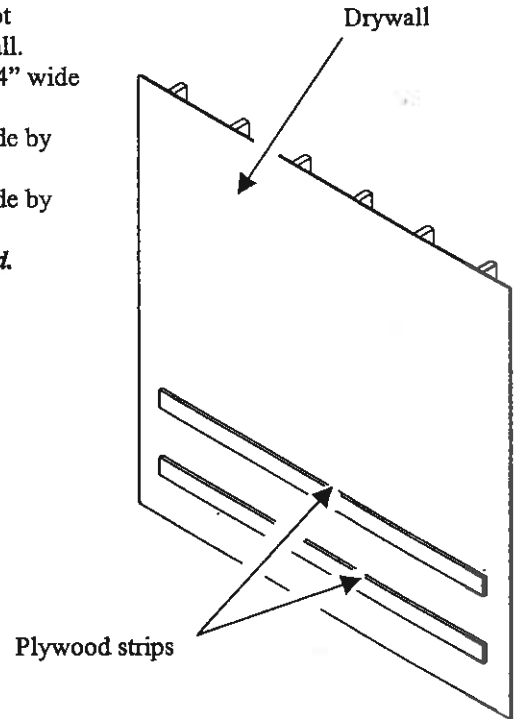

STEP #2: WALL COUNTER CANTILEVER

- 1) Confirm location of cantilevers with floor plan. (The spacing between cantilevers must not exceed 24")
- 2) Attach cantilever to wall with #10 x 1" screws.
- 3) Secure counter to cantilevers using #10 x 1" screws.
- 4) For 12" or 18" cantilevers secure to wall with #10x1.5" screws, attach oak cover with a construction adhesive.
- 5) Tape oak cover until adhesive has had sufficient time to dry.
- 6) If drywall attachment make sure step 1 is completed.

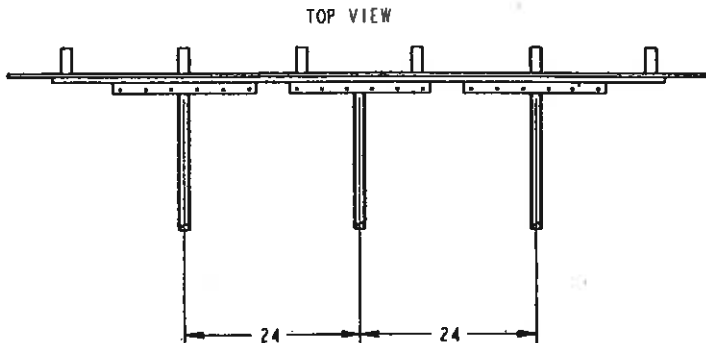
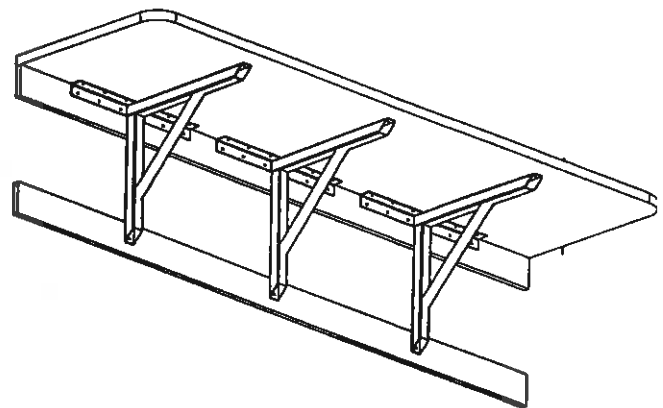

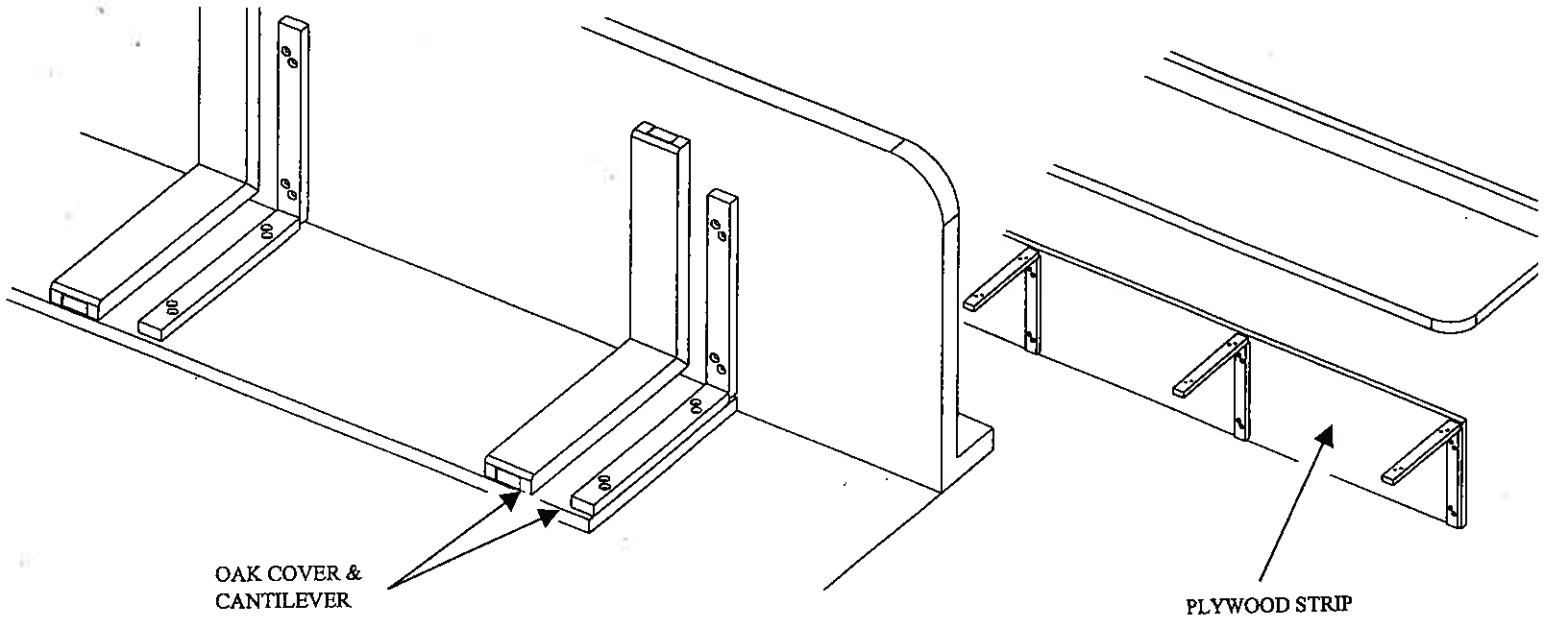

STEP #3: WALL MOUNT TABLE CANTILEVER

- 1) Confirm location of cantilever with floor plan.
- 2) Attach cantilever to wall with #10x1" screws.
- 3) Secure top to cantilever with #10x1" screws.
- 4) If drywall attachment, make sure step #1 is completed.

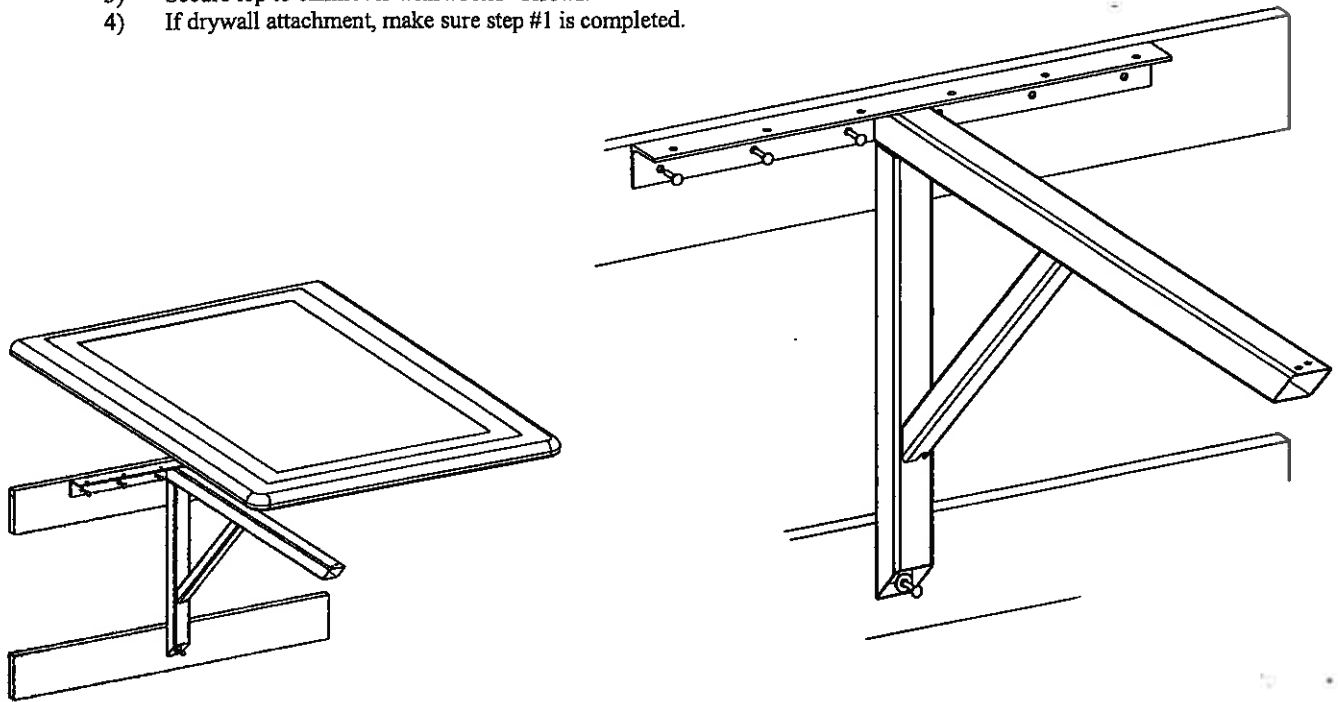

STEP #4: CARE

- 1) Clean furniture and protect until ready for use.

CARE & MAINTENANCE:

Periodic maintenance is necessary to ensure long term durability and customer satisfaction. Buyers must therefore advise end user of the following:

To prevent personal injury, furniture must be inspected regularly for loose screws, glides and casters, cracked or broken welds, cracked laminate, wood splinters and general instability. Furniture that is damaged or appears to be unstable must be immediately removed from service and relaced or repaired using only factory authorized parts and methods. Contact Plymold Customer Service for assistance and further instructions.

Wood Finish: Coat wood with a hard paste wax every three to four months during the first years of use. After the first year, application can be less frequent. To clean, use liquid cleaner-wax polish combination. Do not use abrasive household solvents. Water spills on the surface should be wiped off immediately.

Metal Finish: Wipe with a damp cloth. To remove dirt, brush the surface with a soft bristled dry brush. For stubborn stains and grease, use soap and water.

Vinyl Upholster: Use a liquid detergent suitable for cleaning vinyl. After cleaning, wipe the surface with a cloth dampened with warm water.

Vinyl Edge and Dur-A-Edge: Use a liquid detergent suitable for cleaning vinyl. After cleaning, wipe the surface with a cloth dampened with warm water.

Laminate: To remove stains, wipe the surface with a damp cloth using soap or liquid detergent. Remove stubborn stains with a damp paste of baking soda. Leave on for a minute, then blot away. Abrasive cleaners should not be used. Acid based products spilled on the surface should be wiped off immediately, then rinsed.

PRODUCT WARRANTY

Plymold warrants all products manufactured and/or marketed by Plymold to be free from defects in material and workmanship under normal usage and service for one (1) year from date of purchase unless extended warranties have been established for specific products. The customer assumes responsibility for normal wear and tear.

This Warranty Agreement excludes all products or component parts that, in the opinion of Plymold, have been subjected to negligent use, misuse, alteration, accident or improper installation. Plymold reserves the right to make design changes, improve design or change specifications at any time without any contingent obligation to owners of products previously sold.

Plymold shall not be held responsible by customer potential customers for failure to perform any of the obligations of this Warranty Agreement if such failures are the result of circumstances of Force Majeure such as, but not limited to floods, earthquakes, transportation strikes, labor disputes with any outside suppliers, or any other conditions beyond the control of Plymold.



615 Centennial Drive Kenyon, MN 55946
Phone 507-789-5111, 800-PLYMOLD (759-6653) Fax: 507-789-8315
Email: seating@plymold.com www.plymold.com