

Installation Manual

Flat Benches

Island Style

Z000000127

Revised 03/0317

Unpacking Your Shipment

Unpack and identify each component in each box that you received. If your shipment is missing parts, or too many parts were shipped, please contact Plymold.

Components

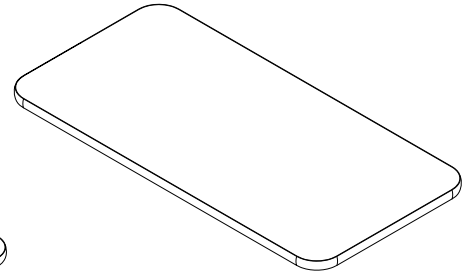
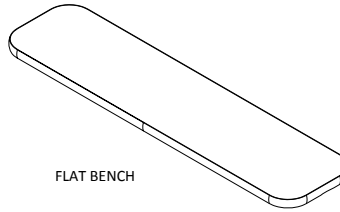
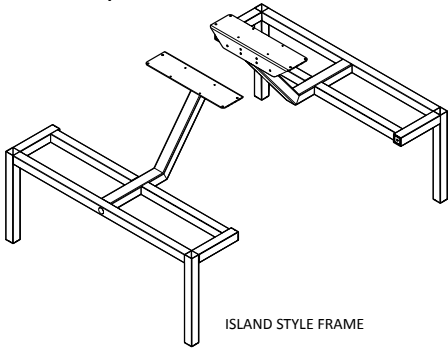

P85794 HARDWARE KIT FLAT BENCH

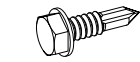
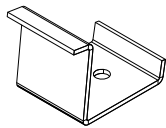

P85888 JUPITER FRAME HARDWARE KIT

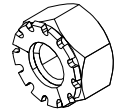
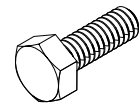

P85889 JUPITER TABLE & FLOOR HARDWARE KIT

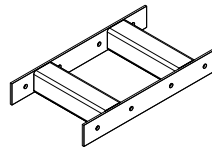
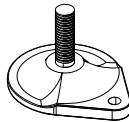
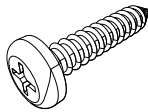

Tools Required



Assembly

Step 1: Glide Assembly - Island Style Frame

- a. Assemble a thread-in glide into the insert in each of the four (4) legs.

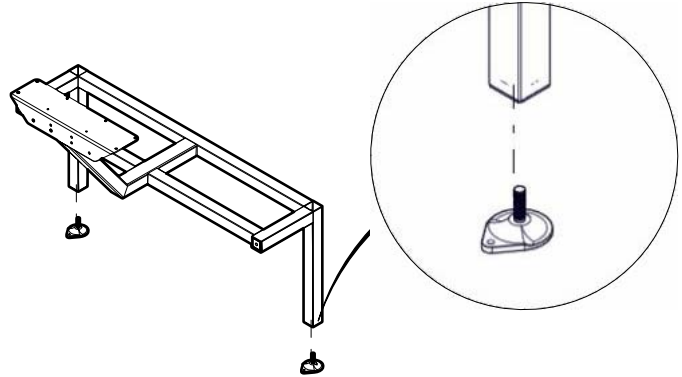

Step 2: Assemble Seat to Frame

- a. **Note: An expansion spacer is required for table tops wider than 24".**

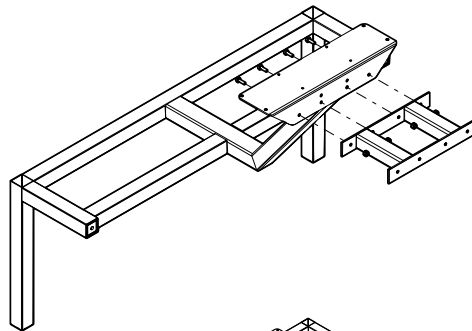

- b. Align the table angle holes.

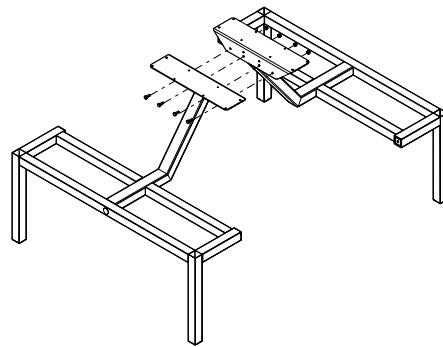

- c. Locate the Jupiter Frame Hardware Kit and fasten the two frame halves together using 1/4-20x3/4" bolts and nuts.

Note: Hand tighten nuts and bolts.

- d. Level table angles.

- e. Tighten nuts and bolts using a wrench.

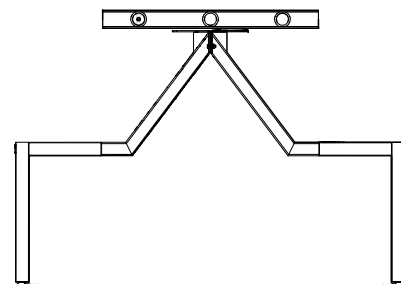

Assembly

Step 3: Assemble Seat to Frame

- Locate Flat Bench hardware kit.
- Position seat centered on island frame.
- Insert short tongue of rear seat hook into the seat plate. Using a flathead screwdriver pry rear seat hook until it pops into place. (4x per Bench) Note: Booth Hooks should be inside the frame.

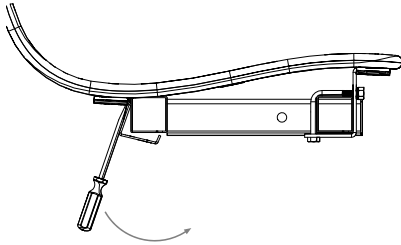

Screw drive shown prying rear seat hook on contour seat. Same method used for flat bench.

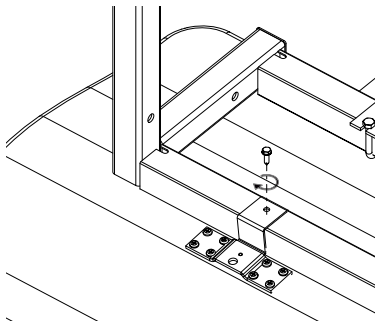
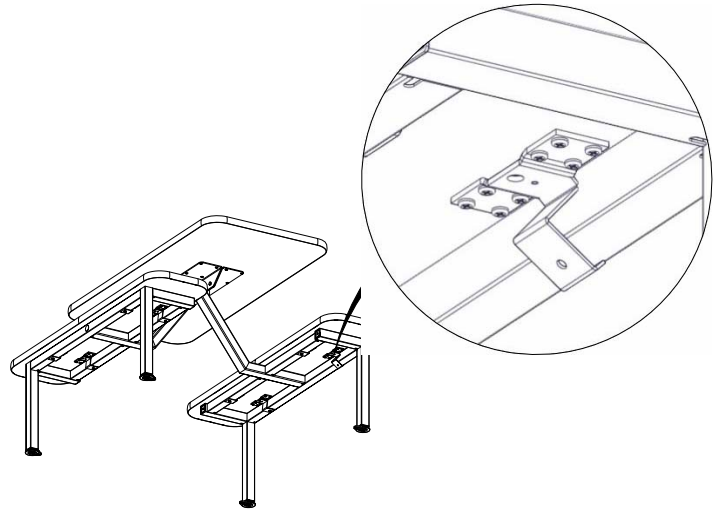

- Now that the seat is installed, insert a self-drilling screw into the hole in the rear seat hook. One screw for each rear seat hook. Do not over tighten.

Step 4: Installing Table Top

- Locate the Jupiter Table & Floor Hardware Kit.
- Place the table top on the frame.
- Position table per drawings below.
- Secure the table top from moving while fastening, using (16) #10 x 1.0" screws.

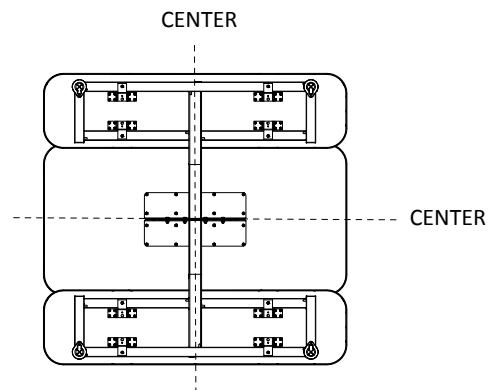

Assembly

Step 5: Position and Level Booth

- a. Confirm location of booth/frames with the floor plan.
- b. Level booth by adjusting glides.

Step 6: Fasten Glides to Floor

- a. Rotate glides to point the mounting hole towards the center of the booth.
- b. With a pencil, mark the hole location on the floor using the holes in the glide.
- c. Turn the glide away 90 degrees from its current position to expose the mark on the floor.
- d. Using a hammer drill and a 1/4" masonry bit, drill a 1 1/4" deep hole on the pencil mark.
- e. Place a plastic anchor in the hole and then rotate glide back so the hole lines up with the plastic anchor in the floor.
- f. Insert a #10 x 1.0" screw through the hole in the glide and secure into the plastic anchor.

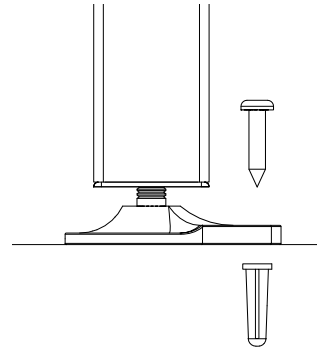

Note: Frames must be anchored to the floor to maintain stability and prevent personal injury.

Step 7: Care.

- a. Clean furniture and protect unit until ready for use.

